

Datasheet

Subject to technical alteration
Issue date: 31.03.2015



Application

Temperature- & Air velocity transmitter for measuring and monitoring air velocities in supply/exhaust air plants, ventilators, regulation flaps and electro damper registers.

Types Available

AVT	Temperature- & Air Velocity Transmitter
AVT-D	Temperature- & Air Velocity Transmitter with LC-Display
AVT-D-R	Temperature- & Air Velocity Transmitter with LC-Display and Relay

Security Advice – Caution



The installation and assembly of electrical equipment must be performed by a skilled electrician.

The device should only be used for the appropriate application. Unauthorised conversions or alteration are prohibited! The modules must not be used in relation with equipment that threatens, directly or indirectly, human health or life or with applications that can result in danger for people, animals or assets. Before connecting devices, the installation must be isolated from the power source!

For devices with controlling units (signal transducers, transmitters, etc.), it is important to make sure that the signal receiving device (actuators, generators, etc.) does not accept damaging or threatening conditions, that may arise from false signals during installation / configuration of the control unit. If necessary, disconnect the signal receiver from any source of power.

CAUTION! Risk of electric shock due to live components within the enclosure, especially devices with mains voltage supply (usually between 90..265 V).

The following procedure must be carried out:

1. Disconnect the device from power.
2. Ensure the device is secured against reconnection.
3. Verify the device is not powered.
4. Prior to reconnection, ensure that the enclosure is securely closed.

Please verify and consult:

- Laws, standards and regulations.
- The current condition of the device at the time of installation, to ensure safe installation.
- The devices technical data and installation manual.



Notes on Disposal

As a component of large-scale fixed installation, Thermokon products are intended to be used permanently as part of a building or a structure at a pre-defined and dedicated location. The Waste Electrical and Electronic Act (WEEE) is not applicable. However, the product may contain valuable materials that should not be recycled rather than disposed as domestic waste. Please note the relevant regulations for local disposal.

Technical Data

Output others:	(optional) Relay (voltage free contact), 230 V ~ / 6 A, 30 V = / 6 A Changer, adjustable switching threshold and hysteresis
Output airflow / temperature:	<u>Temperature:</u> 0..10 V (linear to °C), load min. 1 kΩ or 4..20 mA (linear to °C), load max. 400 Ω <u>Air velocity:</u> 0..10 V (linear to m/s), Load min. 1 kΩ or 4..20 mA (linear to m/s), Load max. 400 Ω
Power supply:	15..24 V = (±10%) or 24 V ~ (±10%)
Power consumption:	0..10V: 35 mA (50 mA with relay) 4..20mA: +40 mA
Measuring range air velocity:	0..2 m/s, 0..10 m/s or 0..20 m/s, selectable at the device
Measuring range temperature:	0..+50 °C
Accuracy Velocity:	0..2 m/s: <0,1 m/s + 5% of measuring value, 0..10 m/s: <0,5 m/s + 5% of measuring value, 0..20 m/s: <1,0 m/s + 5% of measuring value
Accuracy temperature:	<0,5 °C (@velocity > 0,5 m/s)
Display:	LCD for indication of measuring values (optional)
Ambient temperature:	0..+50 °C
Ambient humidity:	max. 85% rH short term condensation
Cable entry size:	M16 with relay option (-R) 2x M16
Protection:	IP54 according to DIN EN 60529
Terminal block:	Terminal block, max. 1,5 mm ²
Enclosure material:	ABS, PC
Pocket material:	Stainless Steel 1.430 (SS304)
Pocket length:	210 mm
Dimensions	90 x 71,5 x 36 mm
Weight:	220 g
Storage temperature:	-20..70 °C
Notes:	Incl. mounting flanges, Adjustable Immersion length: 50..180 mm, using mounting flange

Mounting Advices

The supply cable and control cable for relay should be separated, if high voltage (no safety extra-low voltage) is used as relay contact. Both cables have their own cable entries.

The relay settings need to be done before high voltage (no safety extra-low voltage) is connected to the device. This ensures human protection against electrical shock.

The device is equipped with a lid fixing screw. The screw needs to be used when high voltage (no safety extra-low voltage) is connected to the device.

Terminal Connection Plan

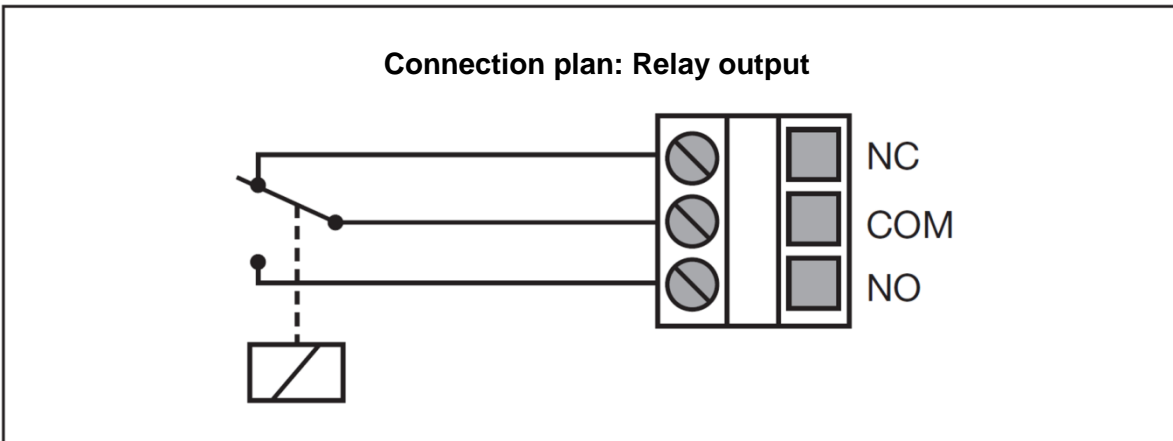
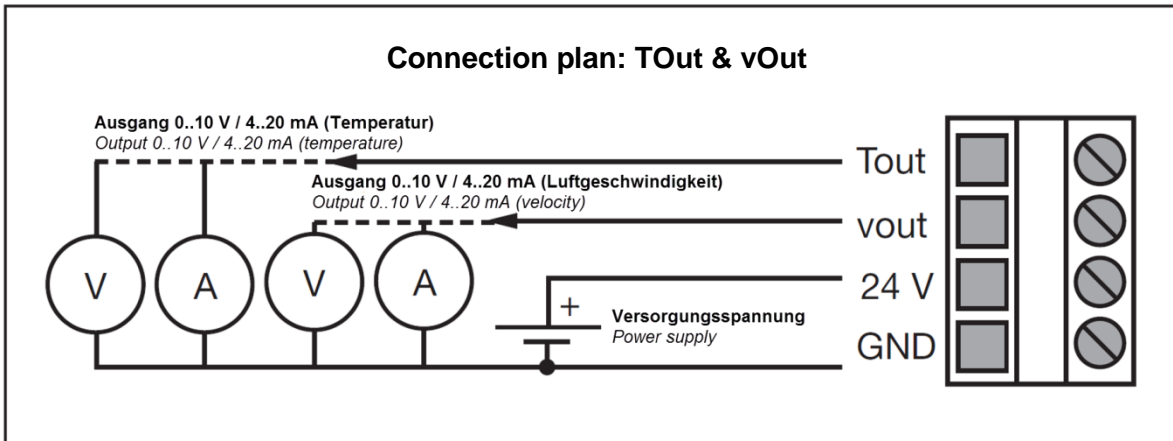
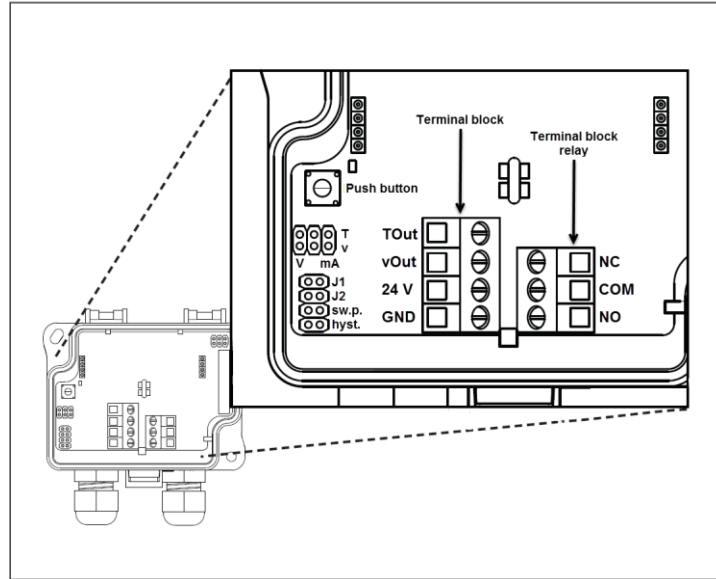

Commissioning

A prerequisite for the operation is a proper installation of all electrical supply, control and sensing leads as well as the pressurized connection line.

Before installing the device, the leak tightness of the pressurized connection lines must be inspected.

The air velocity transmitter AVT is supplied with a special protective cap for the sensitive sensor element against damage during transport. Before installing the AVT, the cap must be removed.

Configuration

1. Jumper setting for measuring range

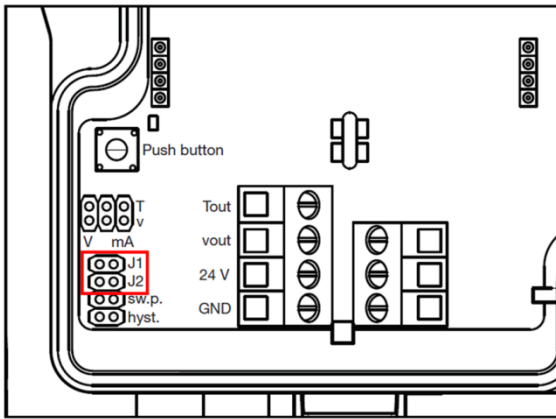

Measuring range: 0..2 m/s		Jumper (J1): installed Jumper (J2): not installed
Measuring range: 0..10 m/s		Jumper (J1): not installed Jumper (J2): installed
Measuring range: 0..20 m/s		Jumper (J1): installed Jumper (J2): installed

2. Output settings (via jumper)

Both outputs (temperature and air velocity) can be configured as a voltage (0..10 V) or current output (4-20mA) independently.

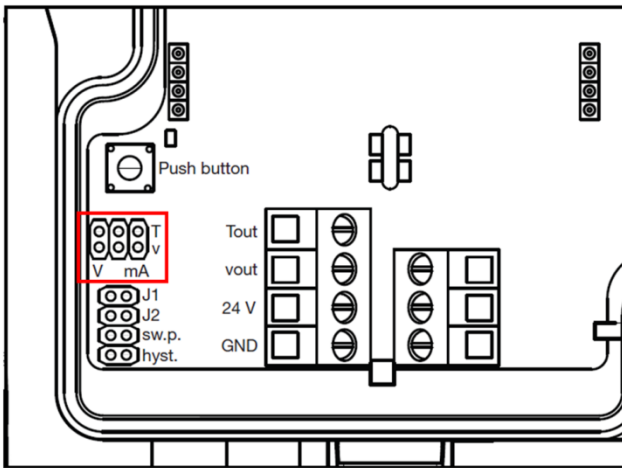

	T Temperature output (Tout): T= Voltage (V) v Air velocity output (vOut): v= Voltage (V) V mA
	T Temperature output (Tout): T= Amperage (mA) v Air velocity output (vOut): v= Amperage (mA) V mA
	T Temperature output (Tout): T= Voltage (V) v Air velocity output (vOut): v= Amperage (mA) V mA
	T Temperature output (Tout): T= Amperage (mA) v Air velocity output (vOut): v= Voltage (mA) V mA

3. Relay configuration (only possible at Type with relay)

a) Switching threshold / Switching-Point

- plug a jumper on pins, which are marked with "sw.p." (switching threshold / Switching Point).
- Pressing the button (push button) repetitive or permanent, the value shown on the display is incremented as long until the desired switching threshold is set. After reaching the range limit, the display jumps back to the start of measuring range.
- After setting the desired value, remove the jumper.

b) Hysteresis

- Insert a jumper on pins that are marked "hyst." (hysteresis).
 - Pressing the button (push button) repetitive or permanent, the hysteresis shown in the display is incremented as long until the desired value is set. After reaching the maximum value, the display returns to the initial value.
 - After setting the desired value, remove the jumper.
- The configuration is complete.

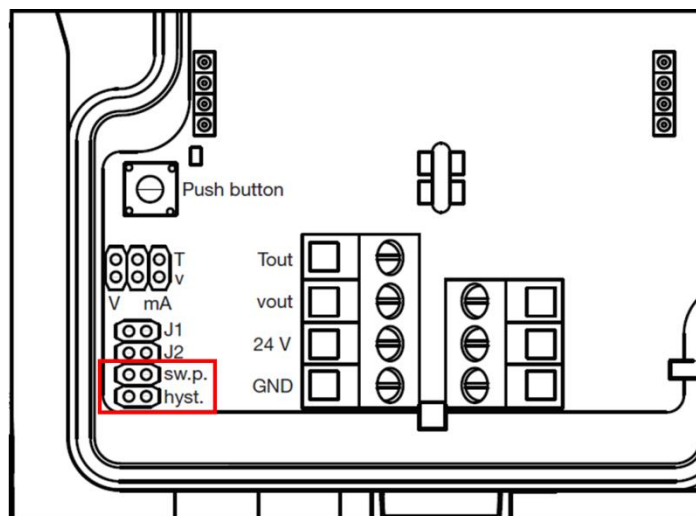

Dimensions (mm)

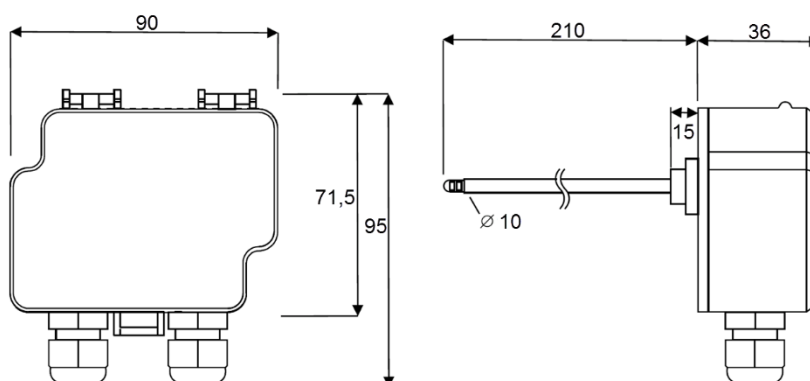

Accessories Included

Mounting flange