

TCL SOLAR

S Class Solar Panel

Product: TCL-MRxxxDT182-58NS
455-465 W | Up to 22.7% efficient



Ideal for residential applications



Framed glass-glass



One-third cut, shingled-cell design



Bifacial energy generation

High energy yield

- Consistent energy production across all weather conditions
- Bifacial energy generation and shingled-cell design

Proven design

- Better shading response
- High-durability frame and heat-strengthened glass

Reliable operation

- Rigorous supply chain qualification procedures
- Easy to install
- Backed by a bankable company

Comprehensive warranty coverage

Product and power coverage	25-30 years
Year 1 minimum warranted output	99.0%
Maximum annual degradation	0.40%

TCL SOLAR

Learn more about TCL Solar panels
www.tclsolar.com/resources



S CLASS POWER: 455-465 W | EFFICIENCY: Up to 22.9%

Electrical Data, Front STC Characteristics¹			
	TCL-MR465DT182-58NS	TCL-MR460DT182-58NS	TCL-MR455DT182-58NS
Nominal Power (P _{nom}) ²	465 W	460 W	455 W
Power Binning	+3/0%	+3/0%	+3/0%
Panel Efficiency	22.9%	22.7%	22.4%
Rated Voltage (V _{mpp})	36.20 V	35.90 V	35.65 V
Rated Current (I _{mp})	12.85 A	12.82 A	12.77 A
Open-Circuit Voltage (V _{oc}) ²	42.49 V	42.20 V	42.00 V
Short-Circuit Current (I _{sc}) ²	13.55 A	13.53 A	13.48 A

BNPI Data³			
Nominal Power (P _{max}) ²	512W	506 W	500 W
Open-Circuit Voltage (V _{oc}) ²	42.49 V	42.34 V	42.12 V
Short-Circuit Current (I _{sc}) ²	14.91 A	14.91 A	14.84 A

Bifacial Gain⁴			
P _{max} with 5% Bifacial Gain	488 W	483 W	478 W
I _{sc} with 5% Bifacial Gain	14.35 A	14.21 A	14.15 A
P _{max} with 10% Bifacial Gain	511 W	506 W	501 W
I _{sc} with 10% Bifacial Gain	15.04 A	14.88 A	14.83 A

Electrical Data	
Bifaciality (φP _{max} /φI _{sc})	80% +/-10%
Bifaciality (φV _{oc})	98% +/-2%
Maximum System Voltage	1500 V IEC
Testing Temperature	-40°C to +85°C
Operation Temperature	-40°C to +70°C (IEC TS 63126)
Maximum Series Fuse	25 A
Power Temp. Coef.	-0.29% / °C
Voltage Temp. Coef.	-0.25% / °C
Current Temp. Coef.	0.045% / °C

Mechanical Data	
Solar Cells	N-Type TOPCon Shingle
Glass	2.0 mm + 2.0 mm, high transmission heat strengthened glass, AR coating on front glass
Junction Box	IP-68, 3 bypass diodes
Connector	Stäubli MC4-EVO2A
Weight	24.8 kg
Max. Load ⁵	Wind: 2400 Pa, 245 kg/m ² front & back Snow: 5400 Pa, 550 kg/m ² front
Impact Resistance	25 mm diameter hail at 23 m/s
Frame	Black Anodized Aluminum Alloy

Packaging Configuration	
Number of modules per pallet	36
Number of pallets per 40ft HQ container	24
Number of modules per container	864

Tests And Certifications	
Standard Tests	IEC 61215, IEC 61730
Fire Rating	Class A (IEC 61730-2 / UL 790)
Protection Class	Class II (IEC 61140)
Quality Certs	ISO 9001:2015, ISO 14001:2015
EHS Compliance	ISO 45001-2018, Recycling Scheme

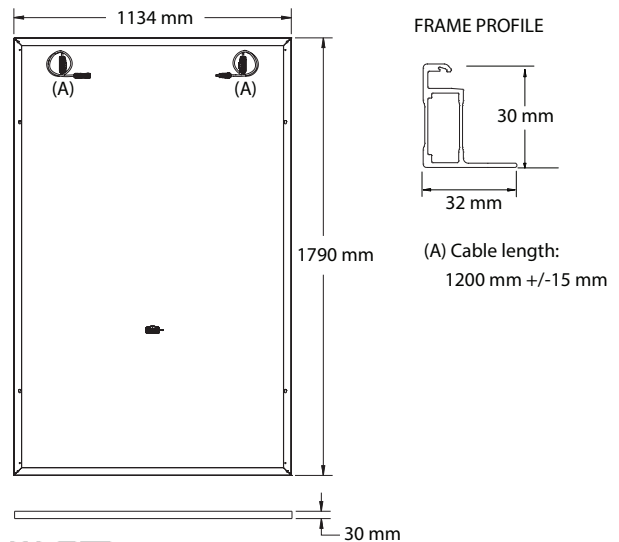

Please read the safety and installation instructions. Visit www.tclsolar.com/resources. Paper version can be requested through techsupport.EN@sunpowerglobal.com

1 Standard Test Conditions (1000 W/m² irradiance, AM 1.5, 25° C). NREL calibration Standard: SOMS current, LACCS FF and Voltage.
 2 Measurement tolerances (P_{max}/V_{oc} +/-3%, I_{sc} +/-4%).
 3 BNPI Test Condition (front 1000 W/m², rear 135W/m² irradiance, AM 1.5, 25° C).
 4 The additional gain from the back side of the panel compared to the power of the front side of the panel at the standard test conditions. It depends on mounting (structure, height, tilt angle etc.) and albedo of the underlying surface.
 5 Test load as per IEC 61215-2 is equal to design load with safety factor = 1.5. See "Safety and Installation Instructions" for details.

